

# Information Sheet

## LiquiPro™ 3-Function Valve

For 300/400 Series Cartridge Valve Type Liquid Ends

### Priming

Priming the pump can be accomplished by a simple 1/4 turn of the Relief Knob. Prime your LMI pump while it is connected to a pressurized line.

### Pressure Relief

Provides protection against excessive system pressure.

### Line Depressurization

By opening the Relief Valve, the discharge line will depressurize without having to loosen or disconnect discharge tubing.

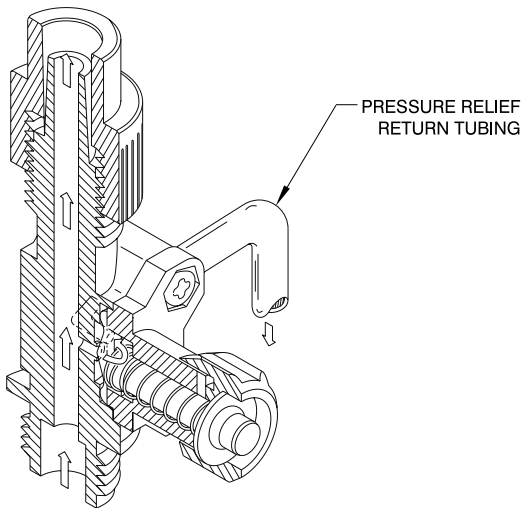
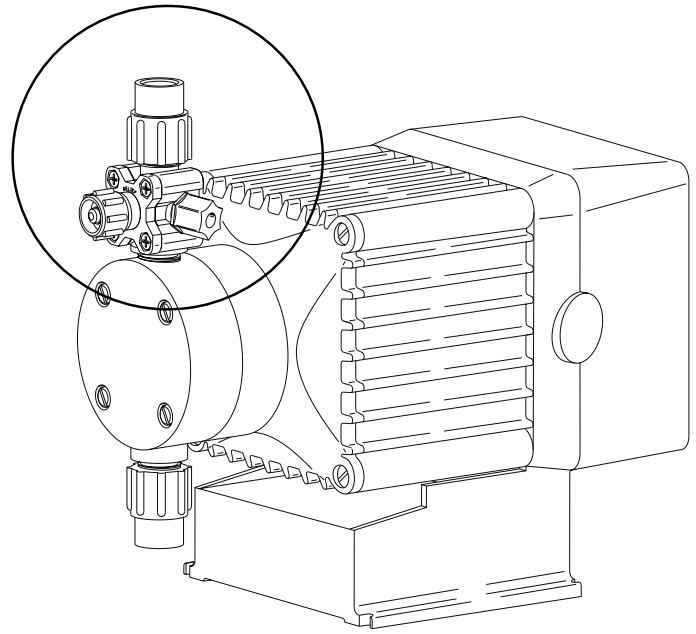

Part No.	Tubing Size	Materials of Construction	
		Diaphragm	Body
36265	1/4" O.D. Tubing	PTFE	PVDF
36266	3/8" O.D. Tubing	PTFE	PVDF
36267	1/2" O.D. Tubing	PTFE	PVDF
36268	1/4" NPT Pipe	PTFE	PVDF
38049	1/4" O.D. Tubing	PTFE	PVC
38054	3/8" O.D. Tubing	PTFE	PVC
38059	1/2" O.D. Tubing	PTFE	PVC
38062	1/4" NPT Pipe	PTFE	PVC

Part numbers are for 300/400 Series LiquiPro™ cartridge valve type Liquid Ends only.



8 Post Office Square  
Acton, MA 01720 USA  
TEL: (978) 263-9800  
FAX: (978) 264-9172  
<http://www.lmipumps.com>



# Instruction Sheet

## LiquiPro™ 3-Function Valve For 300/400 Series Cartridge Valve Type Liquid Ends

### METHOD OF OPERATION

#### A. PRIMING

1. Connect return tubing to (relief) port.
2. Route tubing to solution tank. Be sure the end of tubing is above the maximum solution level (Do not submerge tubing in solution).
3. Turn Relief Knob 1/4 turn to open.
4. Set pump at 80% speed and 100% stroke. Start pump. When solution begins to flow through translucent return tubing, the pump is primed.
5. Stop pump. Turn Relief Knob 1/4 turn to close.

#### NOTE:

- (a) Pump is normally self-priming if suction lift is no more than 5 ft (1.5 m), valves in the pump are wet with water (pump is shipped from factory with water in pump head) and the above steps (A1 through A4) are followed.
- (b) If the pump does not self prime, remove 3-function valve and Discharge Cartridge Valve, and pour water or solution slowly into discharge port until it is filled. Replace Cartridge Valve, and follow steps A1 through A4 thereafter.

#### B. DEPRESSURIZING DISCHARGE LINE

1. It is possible to depressurize discharge line and pump head without removal of tubing or loosening of fittings.

*Be sure injection check valve is properly installed and is operating. If a gate valve or globe has been installed downstream of the injection check valve, it should be closed. Be certain return tubing is connected and run to solution supply tank.*

2. Turn Relief Knob 1/4 turn to open.

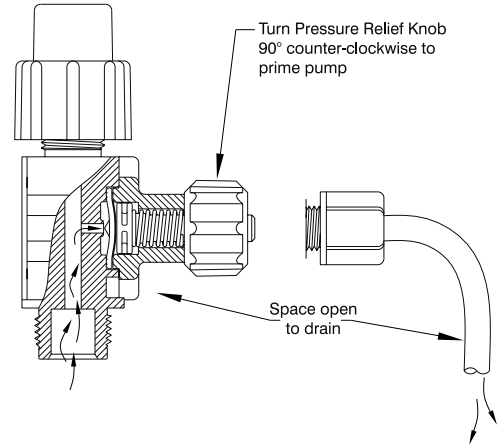

3. Solution should exit the return tubing. The discharge line is now depressurized.
4. If injection check valve is of higher elevation than pump head, disconnecting tubing at injection check valve end will allow air to enter and cause solution to drain back to tank.

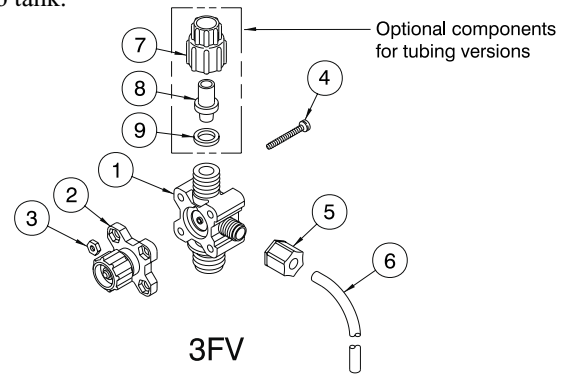

Key No.	Part No.	Description	38049	38054	38059	38062	36265	36266	36267	36268
1	38053	3FV Body, 1/4" PVC	1							
	38058	3FV Body, 3/8" PVC		1						
	38061	3FV Body, 1/2" PVC			1					
	38065	3FV Body, 1/4" NPT PVC				1				
	36288	3FV Body, 1/4" PVDF					1			
	36289	3FV Body, 3/8" PVDF						1		
	36290	3FV Body, 1/2" PVDF							1	
	36291	3FV Body, 1/4" NPT PVDF							1	
2	36260	P/R Cap Asm		1	1			1	1	
	36866	P/R Cap Asm	1			1	1			1
3	25628	Nut	4	4	4	4	4	4	4	4
4	35716	Screw	4	4	4	4	4	4	4	4
5	25631	Coupling Nut	1	1	1	1	1	1	1	1
6	25636-10	Tubing	1	1	1	1	1	1	1	1
	10299	Coupling Nut	1	1			1	1		
7	10411	Coupling Nut			1				1	
	28663	Ferrule	1				1			
9	26136	Clamp Ring		1				1		
	37203	Clamp Ring			1				1	